

TANZ

东莞市台彰机械有限公司

Dongguan Taizhang Machinery Co., Ltd

广东省东莞市茶山镇工兴路10号

Add: No.10, Gongxing Road, Chashan Town, Dongguan City, Guangdong Province

Tel: 0769-8686 9048

Fax: 0769-8532 5873

<https://tzhgjx.1688.com>

www.shihaojx.com

台北市中坡北路50巷3号2F

Add: 2F, No. 3, Lane 50, Zhongpo North Road, Taipei City

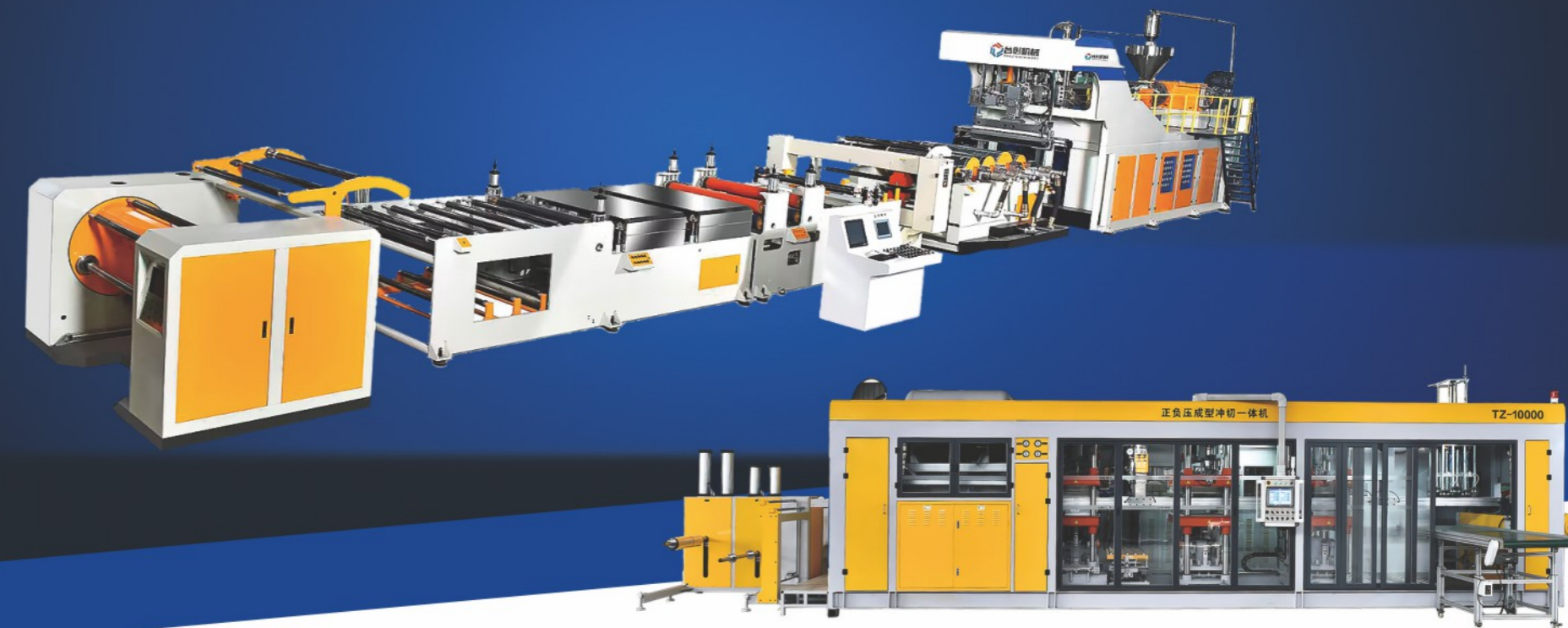

挤出生产线系列
Extrusion Production Line Series

吸塑热成型系列
Vacuum Thermoforming Series

破碎回收及辅机系列
Crushing Recycling And Auxiliary Machine Series

东莞市台彰机械有限公司
Dongguan Taizhang Machinery Co., Ltd

TANZ

COMPANY PROFILEN

公司简介



东莞市台彰机械有限公司成立于2010年，位于“世界工厂”——东莞。15年一直专注于塑料挤出机，热成型多工位一体机，粉碎回收设备等塑料机械产品的研发，生产，销售和服务。产品经过欧盟CE认证及ISO9001认证，产品远销、巴西、泰国、越南、马来西亚、韩国、智利、美国等80多个国家和地区。

Dongguan Taizhang Machinery Co., Ltd. was established in 2010 and is located in Dongguan, known as the "World Factory". For 15 years, we have been focusing on the research and development, production, sales, and service of plastic machinery products such as plastic extruders, hot forming multi station integrated machines, and crushing and recycling equipment. The product has passed EU CE certification and ISO9001 certification, and is exported to more than 80 countries and regions including Brazil, Thailand, Vietnam, Malaysia, South Korea, Chile, and the United States.

挤出生产线系列

Extrusion Production Line Series

- ◆ PET单层或多层共挤片材线
- ◆ PP、PS单层或多层共挤片材线
- ◆ PLA环保降解片材线
- ◆ ABS、HIPS汽车内饰板、冰箱板、箱包板生产线
- ◆ PC、PMMA、GPPS片材生产线、板材生产线
- ◆ PP、PE、PVC、PC板材生产线、波浪板、中空板、格子板生产线

- ◆ PET single-layer or multi-layer co extruded sheet wire
- ◆ PP, PS single-layer or multi-layer co extruded sheet wire
- ◆ PLA environmentally friendly degradation film line
- ◆ Production line for ABS, HIPS automotive interior panels, refrigerator panels, and luggage panels
- ◆ PC, PMMA, GPPS sheet production lines, sheet production lines
- ◆ PP, PE, PVC, PC board production lines, wave board, hollow board, grid board production lines

吸塑热成型系列

Vacuum Thermoforming Series

- ◆ 高速吸塑机
- ◆ 热成型多工位一体机
- ◆ 塑料制杯机
- ◆ High speed vacuum molding machine
- ◆ Hot forming multi station integrated machine
- ◆ Plastic cup making machine

破碎回收及辅机系列

Crushing recycling and auxiliary machine series

- ◆ 破碎机
- ◆ 搅拌机
- ◆ 除湿干燥机
- ◆ 冷水机模温机
- ◆ Crusher
- ◆ Mixer
- ◆ Dehumidification and drying machine
- ◆ Chiller mold temperature machine

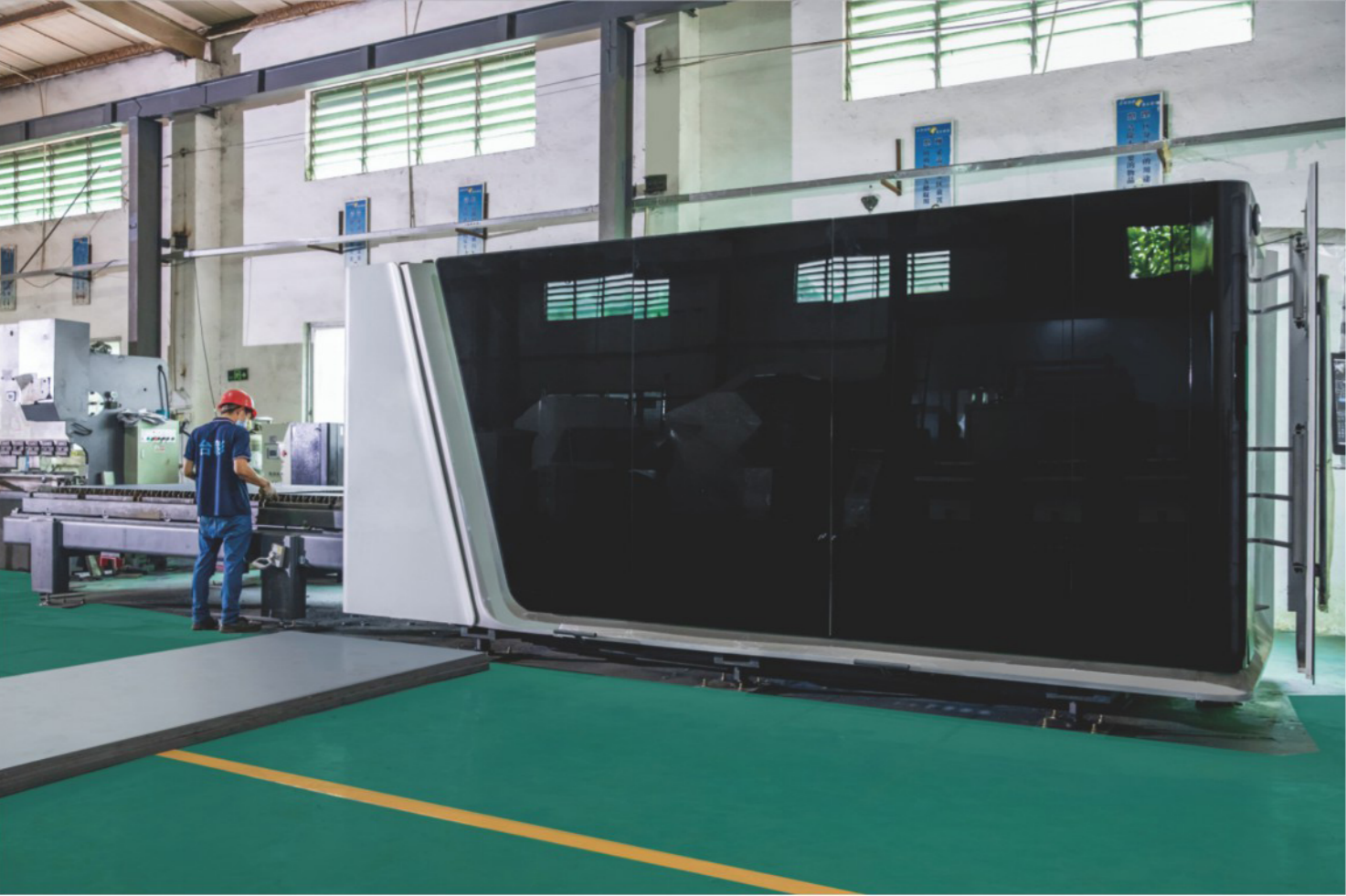

公司拥有多条先进的自动化生产流水线，在生产过程中所能达到的精确度均属行业一流水准。公司高效、快捷、有序的现代化管理，把工程失误控制在最小程度，确保产品的优良品质，为客户提供满意的服务。

The company has multiple advanced automated production lines, and the accuracy that can be achieved during the production process is at the industry's first-class level. The company's efficient, fast, and orderly modern management minimizes engineering errors, ensures excellent product quality, and provides satisfactory services to customers.

PRODUCTION WORKSHOP

生产车间



ENTERPRISE HONOR

企业荣誉



荣誉，意味着肩负更大的责任，印证了我们昨日的辉煌，记录了我们的收获，也确定了我们明日新的起点。

Honor means shouldering greater responsibility, confirming our glory of yesterday, recording our gains today, and determining a new starting point for tomorrow.



CORPORATE CULTURE

企业文化

经营理念: 凝聚真诚、启迪智慧、共享价值、永续经营

行为准则: 使命感成就卓越团队

价值观: 为客户创造价值, 为员工创造生活

人才观: 人才是企业的原动力

服务观: 专业、用心、高效、稳定

Business philosophy: sincere, condensed wisdom, shared value, sustainable management

Code of conduct: the sense of mission success team

Values: to create value for customers, for employees to create life

Talent: talent is the driving force for enterprise

Service concept: professional, intentions, efficient, stable



胜利, 是一种突破!

生命的热情, 从不因沉默而冷却;

台彰人深信着, 最好的进攻就是进攻自己。

Victory, is a breakthrough!

Passion for life, never because of silence and cooling;

TANZ people believed, the best offense is their offensive.

PET单螺杆免干燥排气型片材挤出生产线

PET Single Screw Non Drying Exhaust Type Sheet Extrusion Production Line

功能特点 Functional Features

- ◆ 采用台湾技术自主研发的高转速高产量行星排气螺杆。免结晶干燥。
- ◆ 压辊成型部分采用导热系数不同的合金钢。通过特殊的制造技术和热处理工艺，辊筒温度均匀，棒面散热速度快，材料不粘在辊筒上，产品成型速度快，适用于高生产能力和高质量的应用。
- ◆ 挤出机片材厚度调整采用自动调节系统，机械辊具防撞保护功能。
- ◆ 采用电子手轮操作，实现快速简便的单张规格转换，无需繁琐的操作。片材调整精度高达0.005mm。
- ◆ 全自动片材收卷机标准机最多可卷500公斤直径不超过800mm的片材，也可定制重量和直径更大的卷卷机。我公司还开发了自动绕线机，可同时卷两卷片材，生产能力高。
- ◆ Adopt Taiwan's independently developed high-speed and high-capacity planetary exhaust screw. No crystallization drying required.
- ◆ The forming part of the pressure roller is made of alloy steel with different thermal conductivity. Through special manufacturing technology and heat treatment process, the temperature of the roller is uniform, the heat dissipation speed of the rod surface is fast, the material does not stick to the roller, and the product molding speed is fast, which is suitable for high production capacity and high quality applications.
- ◆ The thickness adjustment of the colliding machine sheet adopts an automatic adjustment system, and the mechanical roller has anti-collision protection function.
- ◆ Electronic handwheel operation is used to achieve quick and easy single-sheet specification conversion without cumbersome operations. Sheet adjustment accuracy is as high as 0.005mm
- ◆ The standard machine of the fully automatic sheet winding machine can roll up to 500 kilograms of sheet material with a diameter not exceeding 800mm. Winding machines with larger weight and diameter can also be customized. Our company has also developed an automatic winding machine, which can roll two rolls of sheets at the same time, with high production capacity

适用范围 Scope Of Application

- ◆ PET塑料片材具有透明度高、无毒无味的环保特点，特别适用于PET在食品包装或其他包装领域的易回收利用。PET是目前理想的热成型包装材料，广泛应用于吸式包装、食品包装、五金包装、医药包装、电子白色包装等领域。
- ◆ 然而，在挤压过程中，PET的吸湿特性可能会降低产品质量。单螺杆机型具有高效的真空排气能力，相对于双螺杆挤出设备的最大优势是，行星式排气螺杆组合结构有效降低PET树脂粘度损失，保持原片材原有韧性。
- ◆ PET plastic sheet has the characteristics of high transparency, non-toxic and odorless and environmentally friendly, and is especially suitable for easy recycling of PET in food packaging or other packaging fields. PET is currently an ideal thermoforming packaging material and is widely used in suction packaging, food packaging, hardware packaging, pharmaceutical packaging, electronic white packaging and other fields.
- ◆ However, during the extrusion process, PET's hygroscopic properties may reduce product quality. The single-screw model has efficient vacuum exhaust capability. The biggest advantage over twin-screw extrusion equipment is that the planetary exhaust screw combination structure effectively reduces the viscosity loss of PET resin and maintains the original toughness of the original sheet.

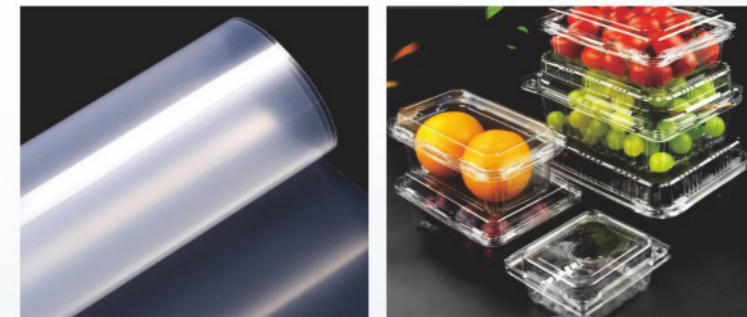

技术参数 Technical Parameter

型号 Model	适应物料 Adapt to materials	螺杆规格 Screw spec	片材厚度 Sheet thickness (mm)	片材宽度 Sheet width	最高挤出量 Max extrusion volume (kg/h)	装机容量 Installed capacity (kw)
TANZ-100PET	PET	Φ100	0.2-1.6	≤850	200-300	210
TANZ-120PET	PET	Φ120	0.2-1.6	≤850	400-500	250
TANZ-130PET	PET	Φ130	0.2-1.6	≤850	600-700	435
TANZ-150PET	PET	Φ150	0.2-1.6	≤850	800-1000	460
TANZ-120/65PET共挤	PET、PLA	Φ120/65	0.2-1.6	≤850	550-650	310
TANZ-150/70PET共挤	PET、PLA	Φ150/70	0.2-1.6	≤850	800-1000	365

* 产品规格若有变更，恕不另行通知。
Wereserverighttochangespecifications without prior notice.

PET双螺杆免干燥排气型片材挤出生产线

PET Twin Screw Non Drying Exhaust Type Sheet Extrusion Production Line

功能特点 Functional Features

- ◆ 应用于PET、PLA片材的生产，无需预结晶干燥系统，并且应用于二次料的生产，具备高产量，低能耗、优塑化的特点。
 - ◆ 螺杆为积木式结构，多元组合，设备使用维护方便的特点。机筒设置双真空排气，保证水气充分排出，对称式薄壁型辊筒提高了冷却效率同时提升了产能和片材品质。
 - ◆ 挤出机配备熔体计量泵定量稳压输出，并且设置压力与速度闭环自动控制整机采用PLC控制，实现参数设置、数据运算及反馈、报警等功能的自动化控制。
- ◆ The production of PET and PLA sheets does not require a pre-crystallization drying system, and it is suitable for the production of secondary materials. It has the characteristics of high output, low energy consumption, and plasticization.
 - ◆ The screw is a building block structure, a multi-combination, and the convenient maintenance of equipment is maintained. The machine is set with dual vacuum exhaust to ensure that the water and gas are exhausted fully. The symmetrical thin-walled roller simplifies improves the cooling efficiency and improves production capacity and sheet quality.
 - ◆ The extruder is equipped with a melting measurement voltage voltage voltage voltage output, and the pressure and speed closed-loop automatic control of the whole machine is controlled by PLC control to realize the self-chemical control of parameter settings, data operations and feedback, alarm and other functions.



技术参数 Technical Parameter

型号 Model	适应物料 Adapt to materials	螺杆形式 Screw form	螺杆规格 Screw spec	片材厚度 Sheet thickness (mm)	片材宽度 Sheet width	最高挤出量 Max extrusion volume (kg/h)	装机容量 Installed capacity (kw)
TZS-75PET	PET、PLA	积木式 Building Block Type	Φ75	0.2-1.6	≤800	450-550	315
TZS-85PET	PET、PLA		Φ85	0.2-1.6	≤1000	600-800	380
TZS-95PET	PET、PLA		Φ92	0.2-1.6	≤950	1000-1200	495
TZS-105PET	PET、PLA		Φ100	0.2-1.6	≤950	1200-1500	505
TZS85-1200	淀粉基降解料 Starch based degradable materials		Φ85	0.3-2.0	≤800	400-500	275

* 产品规格若有变更，恕不另行通知。
We reserve the right to change specifications without prior notice.



PP、PS片材挤出机

PP, PS Sheet Extruder

功能特点 Functional Features

螺杆采用台湾技术设计，具有强制进料、速度快、产能高、质量好等优点。

The screw is designed using Taiwanese technology and has the advantages of fast feeding, high production capacity and good quality.

适用范围 Scope Of Application

依据不同的产品要求，PP/PS 片材挤出生产线可做单层、双层以及多层共挤的片材制品，广泛应用于食品包装领域以及文具领域等，PP透明片材、磨砂片材、双色片材等可用于文具片材。

According to different product requirements, the PP/PS sheet extrusion production line can produce single-layer, double-layer and multi-layer co-extruded sheet products, which are widely used in the field of food packaging and stationery, etc., PP transparent sheet, frosted sheet, two-color sheets, etc. can be used for stationery sheets.



技术参数 Technical Parameter

型号 Model	适应物料 Adapt to materials	螺杆规格 Screw spec	片材厚度 Sheet thickness (mm)	片材宽度 Sheet width	最高挤出量 Max extrusion volume (kg/h)	装机容量 Installed capacity (kw)
TZNZ-100PP	PP、PS、PE	Φ100	0.2-2.0	≤850	PP:350 PS:400	210
TZNZ-120PP	PP、PS、PE	Φ120	0.2-2.0	≤850	PP:450 PS:550	250
TZNZ-150PP	PP、PS、PE	Φ150	0.2-2.0	≤850	PP:800 PS:900	350
TZNZ-120/65PP	PP、PS、PE	Φ150	0.2-2.0	≤850	PP:800 PS:900	460
TZNZ-150/70PP	PP、PS、PE	Φ150	0.2-2.0	≤850	PP:800 PS:900	550

* 产品规格若有变更，恕不另行通知。
Wereserverighttochangespecifications without prior notice.



PP、PS、PE多层共挤出生产线

PP, PS, PE Multi-layer Co Extrusion Production Line

功能特点 Functional Features

该多层共挤片材生产线配有多台挤出机和计量泵，使挤出量稳定、精准。PP PS PE 片材是具有极佳的阻气性、阻湿性，是气体阻隔性能最佳的一种塑料包装材料。主要应用于果冻包装，高档肉食品、快餐米饭等食品包装，药品、化妆品等包装。

The multi-layer co-extrusion sheet production line is equipped with multiple extruders and metering pumps to ensure stable and accurate extrusion volume. PP PS PE sheet has excellent gas barrier and moisture barrier properties, and is a plastic packaging material with the best gas barrier performance. Mainly used in jelly packaging, high-end meat products, fast food rice and other food packaging, medicines, cosmetics and other packaging.

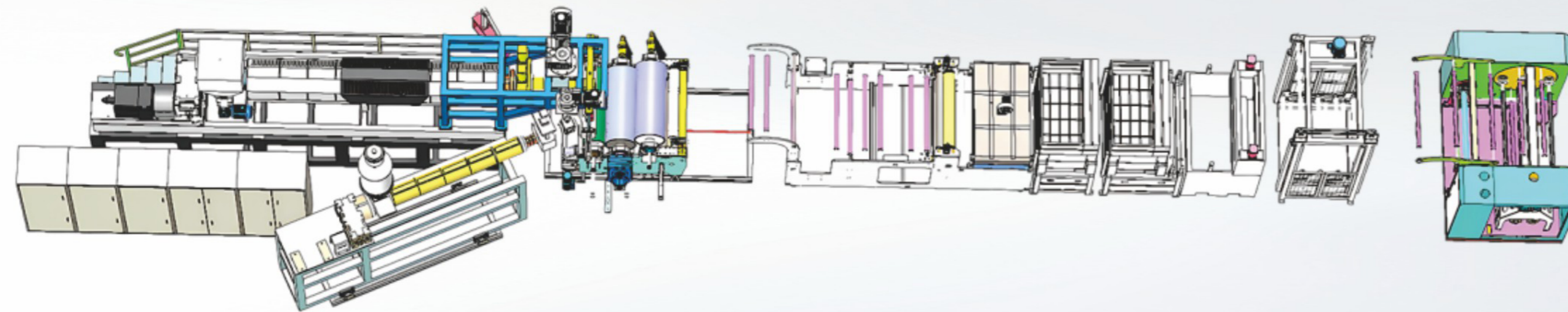

技术参数 Technical Parameter

型号 Model	TANZ100/45/45-1000	TANZ120/45/30/65-1200	TANZ150/45/45-1500
适用原料 Suitable material	PP、PE、PET、PS	PP、PE、PET、PS	PP、PE、PET、PS
片材宽度 Width	800mm	1000mm	1200mm
片材厚度 Thickness	0.5-2mm	0.5-2mm	0.5-2mm
片材厚度 Thickness	300kg/h	400kg/h	650kg/h
设计线速度 Designed line speed	15m/min	20m/min	20m/min
辊筒直径 Calendar diameter	Φ 400mm	Φ 500mm	Φ 600mm

* 产品规格若有变更，恕不另行通知。
* Wereserverighttochangespecifications without prior notice.

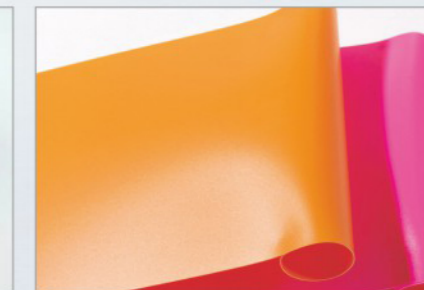

PLA生物降解片材挤出机

PLA Biodegradable Sheet Extruder

功能特点 Functional Features

- ◆ PLA片材挤出生产线适用于PLA（聚乳酸）及改性PLA的生产，PLA(聚乳酸)源自植物资源，可直接用于挤出成型，PLA及解性PLA因其可生物降解，可堆肥，可回收等特点，广泛应用于各种食品包装，五金包装等。
 - ◆ 配有精密分配器，分层均匀，每层比例可调，数字控制精度高。
 - ◆ 倾斜水平压片结构，操作维护更加方便。
 - ◆ 该辊具有独立的动力和同步闭环控制的线速度和挤出速度。
 - ◆ 整机采用PLC控制，实现参数设定、数据计算、反馈、报警等功能的自动控制。
- ◆ The PLA sheet extrusion production line is suitable for the production of PLA (polylactic acid) and modified PLA. PLA (polylactic acid) is derived from plant resources and can be directly used for extrusion molding. PLA and biodegradable PLA are biodegradable and can Compostable and recyclable, it is widely used in various food packaging, hardware packaging, etc.
 - ◆ Equipped with a precision distributor, the layers are evenly layered, the proportion of each layer is adjustable, and the digital control accuracy is high.
 - ◆ The inclined horizontal tableting structure makes operation and maintenance more convenient.
 - ◆ The roller has independent power and synchronous closed-loop control of linear speed and extrusion speed.
 - ◆ The whole machine adopts PLC control to realize automatic control of parameter setting, data calculation, feedback, alarm and other functions.



- ◆ 可降解片材生产线特点:螺杆采用渐变型单螺杆设计，专门针对聚乳酸和玉米淀粉的熔融而设计，同时针对材料的特殊性可开排气。
 - ◆ PLA可降解片材生产线工艺原理: PLA料玉米淀粉料→单螺杆挤出机: 原料熔融塑化→快换滤网→挤出模头成型挤出→立式三次挤出。
 - ◆ 辊式压延机→冷却成型装置→切边机→牵引输送机→自动张力缠绕。
- ◆ Features of biodegradable sheet production line: The screw adopts a gradient single screw design, which is specially designed for the melting of polylactic acid and corn starch. At the same time, The exhaust can be opened according to the particularity of the material.
 - ◆ PLA degradable sheet production line process principle: PLA material corn starch material → single-screw extruder: melting and plasticizing of raw materials → quick-change filter → extrusion die molding and extrusion → vertical three-time extrusion.
 - ◆ Roller calender → cooling forming device → edge trimmer → traction conveyor → automatic tension winding.



技术参数 Technical Parameter

型号 Model	适应物料 Adapt to materials	螺杆规格 Screw spec	片材厚度 Sheet thickness (mm)	片材宽度 Sheet width	最高挤出量 Max extrusion volume (kg/h)	装机容量 Installed capacity (kw)
TPLA-120	PLA、PET	Φ120	0.3-2.0	≤850	PP:450 PS:550	250
TPLA-150	PLA、PET	Φ150	0.3-2.0	≤850	PP:800 PS:900	435

* 产品规格若有变更，恕不另行通知。
Wereserverighttochangespecifications without prior notice.

全自动负压成型裁切一体机(三/四工位)

Fully Automatic Negative Pressure Forming And Cutting Integrated Machine (Three/Four workstations)

功能特点 Functional Features

- ◆ 全伺服驱动，无噪音，无振动，热成型好，速度快。
- ◆ 炉膛自动出料装置可在生产过程中随时放下，不破板，不浪费物料。
- ◆ 电炉温度控制系统采用智能自动补偿控制，一次控制调节器，易于调节温度均匀，使用方便，操作方便，升温快，可在烤箱内上下三次烘烤低温切片。
- ◆ 成型分切模伺服驱动，上下模行程双向可调，上模闭合方向电动可调。在封闭模式下，上下模具的高度和位置可以方便快速地调整；下模合模方向易于接近和缓冲，提高合模速度，避免振动。
- ◆ PLC自动裁切，自动计数，自动输送。
- ◆ 无需费力，只需1-2名工人即可打包。

- ◆ Full servo drive, no noise, no vibration, good thermoforming, fast speed.
- ◆ The automatic discharge device of the furnace can be put down at any time during the production process without breaking the plate or wasting materials.
- ◆ The electric furnace temperature control system adopts intelligent automatic compensation control and a one-time control regulator, which is easy to adjust the temperature evenly, is easy to use, easy to operate, and heats up quickly. It can bake low-temperature slices up and down three times in the oven.
- ◆ The molding and slitting mold is servo driven, the upper and lower mold strokes are bidirectionally adjustable, and the closing direction of the upper mold is electrically adjustable. In the closed mode, the height and position of the upper and lower molds can be adjusted conveniently and quickly; the closing direction of the lower mold is easy to access and cushion, increasing the mold closing speed and avoiding vibration.
- ◆ PLC automatic cutting, automatic counting and automatic conveying.
- ◆ No effort needed, only 1-2 workers can pack it.

适用范围 Scope Of Application

- ◆ 适用于厚度为0.15-2.0mm的PS HIPS,PVC, PET,PP、PE、PS、KPS、GPET、ABS等热塑性材料成型，加工高透明，高拉伸、圆形、方形、不规则、上下双向拉伸，翻边产品。
- ◆ 电子：电子半成品生产线周转托盘，电子产品成本包装等
- ◆ 食品类：冷冻食品包装托盘、冰淇淋盖、冰淇淋盒、食品包装托盘、快餐包装盒、餐盘、咖啡饮料杯盖、熟食包装盒等。
- ◆ 果蔬：生鲜食品包装托盘、水果包装盒等。
- ◆ 医药制品：注射托盘、固体药物托盘、瓶托盘等。
- ◆ 电器类：冰箱内衬、电器真空成型配件、小家电包装等。
- ◆ 工具类：工具成品包装等。
- ◆ 酒精：酒瓶包装等固定托盘。
- ◆ 农业：花盆、育苗盘等。

- ◆ Suitable for molding thermoplastic materials such as PS HIPS, PVC, PET, PP, PE, PS, KPS, GPET, ABS with a thickness of 0.15-2.0mm, processing high transparency, high stretch, round, square, irregular, up and down bidirectional Stretch, flange products.
- ◆ Electronics: Electronic semi-finished product production line turnover trays, electronic product cost packaging, etc.
- ◆ Food: frozen food packaging trays, ice cream lids, ice cream boxes, food packaging trays, fast food packaging boxes, dinner plates, coffee drink cup lids, cooked food packaging boxes, etc.
- ◆ Fruits and vegetables: fresh food packaging trays, fruit packaging boxes, etc.
- ◆ Pharmaceutical products: injection trays, solid drug trays, bottle trays, etc.
- ◆ Electrical appliances: refrigerator linings, vacuum forming accessories for electrical appliances, packaging of small household appliances, etc.
- ◆ Tools: packaging of finished tools, etc.
- ◆ Alcohol: Fixed trays for wine bottle packaging and so on.
- ◆ Agriculture: flower pots, seedling trays, etc.



技术参数 Technical Parameter

名称 Name	规格 Specifications	备注 Remarks
成型长度 Forming length	400mm-850mm	
成型宽度 Forming width	420mm-720mm	
成型高度 Forming height	0-110mm	
材料最小、最大的厚度 Minimum and maximum thickness of material	PS: 0.16-2.0mm PP: 0.16-1.6mm PET/PVC: 0.16-1.2mm	
使用电压 Using voltage	380V 3N 50HZ	三相四线50Hz Three-phase four-wire 50HZ
电炉额定功率 Electric furnace rated voltage	30KW	最大40-50KW Max 40-50KW
生产速度 Production speed	3秒/模 3 seconds/mode	20模/分钟 20 mold/minutes
冲孔最大压力 Maximum punching pressure	50吨 50tons	
裁切最大压力 Maximum cutting pressure	50吨 50tons	
成型机承受最大压力 Molding machine withstands maximum pressure	55吨 55tons	
电炉加热面积 Electric furnace heating area	870*750mm	上、下炉84个发热砖 84pcs heating bricks for upper and lower furnaces
机器主机尺寸 Machine host size	L6500*W2150*H2800mm	三工位（成型、冲切、堆叠） Three stations (forming, punching, stacking)
整机总长度 Overall length of the machine	8800mm	主机、送料机、卷废料机 Host, feeder, roll scrap machine
整机总重量 Total machine weight	9吨 9tons	主机、送料机、卷废料机 Host, feeder, roll scrap machine



* 产品规格若有变更，恕不另行通知。
Wereserverighttochangespecifications without prior notice.

全自动正负压成型裁切一体机(三/四工位)

Fully Automatic Positive And Negative Pressure Forming And Cutting Integrated Machine (Three/Four workstations)

功能特点 Functional Features

全自动多工位正负压吸塑成型机采用塑料片材真空成型技术、是集机、电、气一体化设计，采用微电脑及工控可编辑器PLC控制，整个系统HMI（人机界面）。凹凸模皆可成型。三工位：成型，冲切，堆叠，四工位：成型，冲切，打孔，堆叠。成型设备一次性输送完成的塑料片材，减少人工，操作便捷，提高生产效率，车间整洁、自动化程度高，专用于热成型和产品自动冲切的流水式生产线。

The fully automatic multi-station positive and negative pressure blister molding machine adopts plastic sheet vacuum forming and extrusion technology. It is an integrated design of machinery, electricity and gas. It is controlled by microcomputer and industrial control editor PLC. The entire system HMI (human machine interface). Both concave and convex molds can be formed. Three stations: forming, punching, stacking, four stations: forming, punching, punching, stacking. The molding equipment transports the completed plastic sheets at one time, reducing labor, making the operation convenient, and improving production efficiency. The workshop is clean and highly automated. It is a flow-type production line dedicated to thermoforming and automatic punching of products.



适用范围 Scope of Application

适用于厚度为0.15-2.0mm的PS HIPS,PVC, PET,PP、PE、PS、KPS、GPET、ABS等热塑性材料成型，加工高透明，高拉伸、圆形、方形、不规则、上下双向拉伸，翻边产品、可生产塑料饭盒，电子托盘、食品包装盒、医药包装盘、工具成品包装、育苗盘、一次性碗、盖、碟子等塑料产品。

Suitable for molding thermoplastic materials such as PS HIPS, PVC, PET, PP, PE, PS, KPS, GPET, ABS with a thickness of 0.15-2.0mm, processing high transparency, high stretch, round, square, irregular, up and down bidirectional Stretching and flanging products can produce plastic lunch boxes, electronic trays, food packaging boxes, medical packaging trays, finished tool packaging, seedling trays, disposable bowls, lids, plates and other plastic products.

技术参数 Technical Parameter

名称 Name	规格 Specifications	备注 Remarks
成型长度 Forming length	400mm-850mm	
成型宽度 Forming width	420mm-720mm	
成型高度 Forming height	0-110mm	
适应材质 Adaptive material	PS, PP, PET, PVC, BOPS, PLA, etc.	
使用电压 Voltage	380V 3N 50HZ	三相四线50HZ Three-phase four-wire 50HZ
电炉额定电压 Electric furnace rated voltage	45KW	最大109KW Max 109KW
生产速度 Production speed	3秒/模 3 seconds/mold	20模/分钟 20 mold/minutes
冲孔最大压力 Maximum punching pressure	50吨 50 tons	
裁切最大压力 Max cutting pressure	50吨 50 tons	
成型机承受最大压力 Max pressure of molding machine	55吨 55 tons	
电炉加热面积 Electric furnace heating area	1750*750mm	6排*14个发热砖 6 rows*14pcs hot bricks
机器主机尺寸 Machine host size	L8800*W2150*H2800mm	四工位（成型、冲孔、裁切、堆叠） Four stations (forming, punching, cutting, stacking)
整机总长度 Overall length of the machine	12300mm	主机、送料机、卷废料机 Host, feeder, roll scrap machine
机器总重量 Total machine weight	11吨 11tons	主机、送料机、卷废料机 Host, feeder, roll scrap machine

* 产品规格若有变更，恕不另行通知。
We reserve the right to change specifications without prior notice.



高速吸塑成型机

High Speed Vacuum Molding Machine

功能特点 Functional Features

- ◆ 上下模具采用伺服电机恒速驱动，确保产品拉伸成形精度高。
- ◆ 采用伺服驱动，全电脑PLC控制，具有存储记忆和校正功能(精度±1mm)，并具有出膜功能，避免浪费膜。送料采用自动设计。
- ◆ 为配合不同材质的成型，真空位移采用双阀体与阀门互补设计，保证拉伸性和高难度产品的快速成型。
- ◆ 为保证不同规则产品的成型稳定性，脱模设有上模、上模重复或多频率模式可供选择。
- ◆ 电炉采用闭式水平往复设计，温控采用恒压独立控制。加热稳定，补料均匀，可有效解决PET材料发白、变形等不良浪费现象，节电40%以上。
- ◆ 增加冷却装置和快速冷水喷雾，并设置辅助脱模喷雾功能，加快生产速度，效率为比传统机器快40%以上。

- ◆ The upper and lower molds are driven by servo motors at constant speed to ensure high precision of product stretching.
- ◆ Adopting servo drive and full computer PLC control, it has storage memory and correction functions (accuracy ± 1mm), as well as film exit function to avoid film waste. The feeding adopts automatic design;
- ◆ To match the molding of different materials, the vacuum displacement adopts a dual body and valve complementary design, ensuring stretchability and rapid molding of difficult products;
- ◆ To ensure the forming stability of products with different rules, demolding is equipped with upper mold, top mold repetition, or multiple frequency modes to choose from;
- ◆ The electric furnace adopts a closed horizontal reciprocating design, and the temperature control adopts constant pressure independent control. The heating is stable and the replenishment is uniform, which can effectively solve the problem of PET materials whitening, deformation and other adverse waste phenomena, saving more than 40% of electricity;
- ◆ The cooling device and rapid cold water spray are increased, and the auxiliary demoulding spray function is set to accelerate the production speed, and the efficiency is more than 40% faster than the traditional machine.



适用范围 Scope of Application

- ◆ 适用于厚度为0.15-3.0mm的PS HIPS,PVC, PET,PP、PE、PS、KPS、GPET、ABS等热塑性材料成型，加工高透明，高拉伸、圆形、方形、不规则、上下双向拉伸，翻边产品。
- ◆ 广泛用于玩具、五金、化妆品、电子产品(如电池、电子元器件等)、食品(如水果托盘、零食盒、饼干盒、食品托盘、托盘等)、药品等的封口包装。
- ◆ Suitable for molding thermoplastic materials such as PS HIPS, PVC, PET, PP, PE, PS, KPS, GPET, ABS with a thickness of 0.15-3.0mm, processing high transparency, high stretch, round, square, irregular, up and down bidirectional Stretch, flange products.
- ◆ It is widely used in the sealing and packaging of toys, hardware, cosmetics, electronic products (such as batteries, electronic components, etc.), food (such as fruit trays, snack boxes, biscuit boxes, food trays, trays, etc.), medicines, etc.

技术参数 Technical Parameter

名称 Name	产地、品牌 Place of origin, brand	规格、备注 Specifications, Remarks
真空泵 Vacuum pump	传力 Weili Rietschle	100m ³ /HR 4HP
喷枪 Spray gun	台彰定制 Taizhang customization	A100-P10
调温控制 Temperature control	奥仪 Aoyi	奥仪 Aoyi
气缸 Cylinder	"Yade Rong" TaiZhang Customization	8kg/cm ²
电磁阀 Solenoid valve	CKD	FS3 Series/FS2 Series
发热砖 Heating brick	Ceramicx/Elstein	125x125mm 220V/650W
冷水机 Chiller	Taizhang Custom	3HP
中间继电器 Intermediate relay	欧姆龙 Omron	MK3P-1
水、油隔 Water, oil isolation	CKD	三联体 Triple
控制面板档制 Control panel	和泉idec / 施耐德 Hequan idec / Schneider	ASS系列 ASS Series
控制开关 Control switch	富士 Fuji	EA系列 EA Series
触摸屏 Touchscreen	威伦 Willen	10英寸 10 inches
伺服系统 Servo system	赛孚德定制 Safide customization	3.8KW

* 产品规格若有变更，恕不另行通知。
Wereserverighttochangespecifications without prior notice.



全伺服制杯机

Full servo cup making machine

功能特点

Functional Features

- ◆ 一次性塑料板杯热成型机专业称为塑料热成型机。
- ◆ 本设备成型面积可达750*480mm,最大深度可达180mm。
- ◆ 此深度可用于塑料奶茶杯、咖啡杯、一次性水杯等。
- ◆ 调整深度也可以不用塑料盒来做,如:外卖快餐盒、保鲜托盘、蛋托、水果盒、塑料盖等。
- ◆ Disposable plastic plate cup thermoforming machine is professionally called plastic thermoforming machine.
- ◆ The moulding area of this machine is up to 750*480mm and the maximum depth is up to 180mm.
- ◆ This depth can be used for plastic milk tea cups, coffee cups, disposable water cups and so on.
- ◆ Adjusting the depth can also be done without plastic boxes, such as: takeaway fast food boxes, fresh trays, egg trays, fruit boxes, plastic lids and so on.

产品描述

Product Description

- 成型方式:正压成型
- 模具面积:长度:350-450mm宽度:450mm-750mm
- 成型深度:成型最大深度为180MM
- 材料的最大、最小厚度:0.3-2.2MM
- 适应材质:PP、PS、PET、PVC等
- 总功率:装机容量180KWV(最大功率)
- 上拉伸工位:汇川伺服7.5KW
- 下成型工位:汇川伺服 15KV
- 送片机构:5.5KW伺服汇川拉片
- 操作系统:“汇川”15寸彩色触摸屏
- 电磁阀、水、油隔:日本“CKD”
- 发热砖:德国发热砖“爱尔斯坦”“JNNAN”上炉108块800W、下炉99块800W,长3000MM
发热面积
- 设备主要电器配置:汇川伺服,日本富士
- 冷却方式:冷水机一台,10HP(压缩机"日本松下或"美国谷轮")
- 采用RLC可编程控制及人机界面“汇川”15寸彩色触摸屏操作系统,此系统能大大增强各
动作流程
稳定性及反应速度
- 具有1000组的记忆功能,能储存产品的生产数据,下次生产时将旧数据调出即可生产
- 部分气缸:志成升
- 继电器:法国“施耐德”
- 空气开关、接触器、行程开关:日本“富士FUJI
- 主体机架:钢板、角铁、生铁、不锈钢为国产
- 链条:东风
- 路轨:主体铝型材,链托45#钢材,盖板304不锈钢组合
- 工位自动加油泵润滑
- 全机最大耗电量:180KWV,实际消耗功率约80KW电压:380V50HZ
- 设备尺寸:整机长约6.2米、宽1.8米、高3.2米重量约8吨

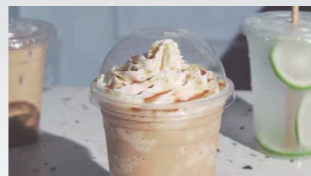
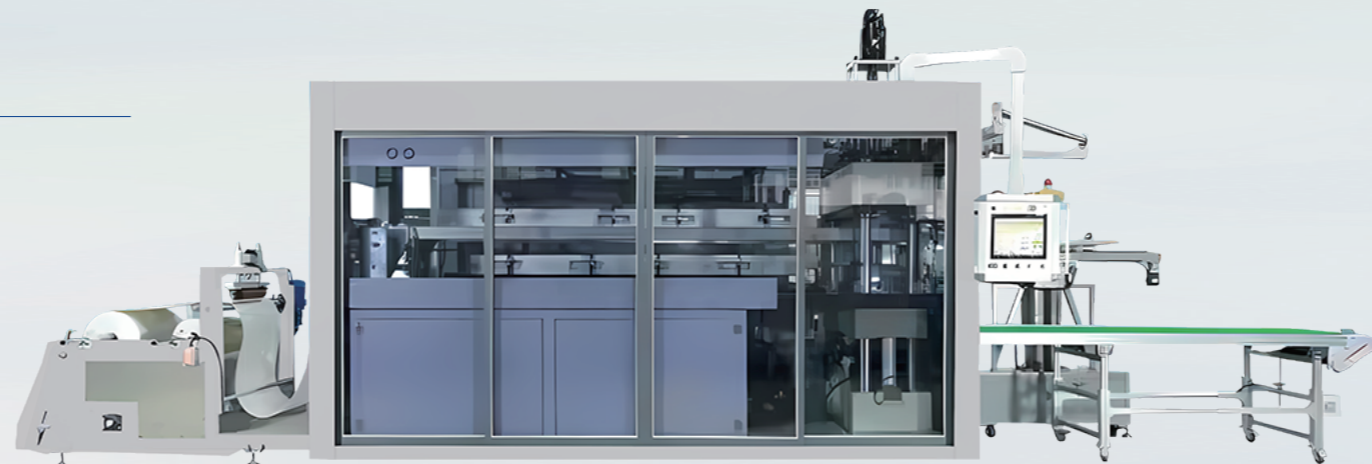

- Forming method:Positive pressure moulding
- Mould area:Length:350-450mmWidth:450-750mm
- Depth of moulding:Maximum depth of moulding:180mm
- Maximum and minimum thickness of material:0.3-2.2MM
- Adaptation material: PP, PS, PET, PVC, etc.
- Total power: installed capacity of 180KWV (maximum power)
- Upper stretching station: Huichuan with the service 7.5KW
- lower forming station: Huichuan servo 15KV
- send piece of mechanism: 5.5KW with the same shares of the Huichuan pulling sheet
- operating system: ‘Huichuan’ 15-inch colour touch screen
- solenoid valve, water, oil isolation: Japan ‘CKD’
- heating brick: Germany heating brick ‘Elstein’ ‘JNNAN’ on the furnace 108 pieces of 800W, the lower furnace 99 pieces of 800W, long 3000MM heat area
- equipment, the main electrical configuration: Huichuan servo, Japan Fuji
- Cooling: a chiller, 10HP (compressor ‘Japan Panasonic or’ U.S. ‘Copeland’)
- RLC programmable control and human-machine interface ‘Huichuan’ 15-inch colour touch-screen operating system, this system can greatly enhance the action flow
Stability and response speed
- With 1000 sets of memory function, can store the production data of the product, the next production will be the old data can be transferred to production
- Part of the cylinder: Zhicheng rise
- Relay: France ‘Schneider’ .
- Air switch, contactor, travel switch: Japan ‘Fuji FUJI
- Main frame: steel plate, angle iron, pig iron, stainless steel for domestic production
- Chain: Dongfeng
- Track: main body aluminium profile, chain support 45# steel, cover plate 304 stainless steel combination
- Workstation automatic oil pump lubrication
- The maximum power consumption of the whole machine: 180KWV, the actual power consumption of about 80KW Voltage: 380V50HZ
- equipment size: machine length of about 6.2 m, width 1.8 m, height 3.2 m weight of about 8 tonnes

技术参数

Technical Parameter

型号	TZF-730	TZF-850
最大模具尺寸Maximum mould size	750*450mm	850*600mm
最大成型深度Maximum moulding depth	125-180mm	180mm
片材厚度Sheet thickness	0.3-1.8mm	0.3-1.8mm
最大成型速度Maximum moulding speed	30次/分钟/ times/minute	30 次/分钟/times/minute
空气压力 Air pressure	0.6-0.8mpa	0.69-0.8mpa
耗气量Air consumption	3.0m³/分钟/min	3.0m³/分钟/min
最大片材宽度Maximum sheet width	760mm	760mm
适用片材Applicable Sheet	PP,PS,HIPS,PET,PVC,PLA	
电源Power supply	380V,三相四线/three-phase four-wire	
额定功率Rated power	190kw	150kw
使用功率Used power	80kw	70kw
重量Weight	约9吨/Approx. 9 tonnes	约8吨/8 tonnes

制杯吸塑在线粉碎机

Cup-making Blister Online Crusher

功能特点 Functional Features

粉碎机部分 Crusher part

- ◆ 刀具采用名牌厂家的特殊钢制造而成，硬度高、韧性好、耐磨性强，特别坚固耐用，便于粉碎各种不同的软硬料，破碎能力强。
- ◆ 机体采用优质钢板焊接加工而成，坚固耐用，永不爆裂。
- ◆ 机架采用国标槽钢焊接而成，并配有螺丝固定装置，保持机器的稳定性。
- ◆ 刀架采用空心式结构设计，运转稳定，风阻小，散热快，且坚固耐用。
- ◆ 轴承采用名牌厂家的轴承，稳定、耐用。飞轮、皮带轮经过精细铸造，精密加工而成，坚固耐用。
- ◆ 采用同步皮带传动方式，技术成熟，运作稳定。
- ◆ 操作简单，性能可靠，低噪音，高质量。
- ◆ 粉碎原料的厚度范围为0.5-3mm。(如需粉碎加厚材料,请订购时加以注明。)

- ◆ The knives are made of special steel made by famous brand manufacturers, with high hardness, good toughness, strong wear resistance, especially strong and durable, easy to crush various soft and hard materials, and strong crushing ability.
- ◆ The machine body is welded and processed with high-quality steel plates, which is sturdy and durable. and will never burst.
- ◆ The frame is welded with national standard channel steel and is equipped with screw fixing devices to maintain the stability of the machine.
- ◆ The tool holder adopts hollow structure design, stable operation, low wind resistance, fast heat dissipation, and sturdiness and durability.
- ◆ The bearing adopts the bearing of famous brand manufacturer, which is stable and durable. The flywheel and belt pulley are made of precision casting and precision processing, which are strong and durable.
- ◆ It adopts synchronous belt transmission mode, mature technology and stable operation.
- ◆ Simple operation, reliable performance, low noise and high quality.
- ◆ The thickness of the crushed raw material ranges from 0.5 to 3 mm. (if you need to crush thickened materials, please specify when ordering).

牵引部分 Traction part

- ◆ 牵引主轴采用高强度无缝钢管精密加工，再镀硬铬，美观大方，永不生锈，坚固耐用，符合环保。
- ◆ 机体是由国标钢精密加工制成，美观大方，坚固耐用。
- ◆ 动力部分采用名牌厂家齿轮减速马达，全新一体化设计，方便轻巧，坚固耐用，并配备名牌厂家的变频器，可与主机同步使用，速度可以满足不同客户的需求，质量稳定。

- ◆ The traction spindle is precision processed with high-strength seamless steel pipe, and then plated with hard chrome, which is beautiful and generous, never rusty, durable, and environmentally friendly.
- ◆ The body is made of precision machining of national standard steel, which is beautiful and durable.
- ◆ The power part adopts the gear reduction motor of the famous brand manufacturer. The new integrated design is convenient and light, strong and durable. It is equipped with the frequency converter of the famous brand manufacturer, which can be used in synchronization with the host. The speed can meet the needs of different customers and the quality is stable.

送料风机部分 Feeding fan

- ◆ 送料风机底座由国标角铁焊接而成。同时采用名牌厂家的马达，质量稳定，经久耐用。
- ◆ 风机外壳及叶片采用不锈钢制作，美观大方、永不生锈、环保卫生、坚固耐用。
- ◆ 独特的风叶设计，增加了风压，输送物料能力强且运行稳定。

- ◆ The base of the feed fan is welded by the national standard angle iron, At the same time, it adopts the motor of the famous brand manufacturer, the quality is stable, and it is durable.
- ◆ The fan shell and blades are made of stainless steel, which is beautiful and generous, never rusty, environmentally friendly and sanitary, strong and durable.
- ◆ The unique fan blade design increases the wind pressure, has strong material conveying capacity and stable operation.



产品描述 Product Description

制杯在线破碎机主要适用于与制造环保饮用杯、碗等包装机械(制杯机、热成型机)配套使用。

Cup-making blister online crusher is mainly suitable for matching with packaging machinery (cup making machine, thermoforming machine) for manufacturing environment-friendly drinking cups and bowls.

技术参数 Technical Parameter

型号 Model	TZXS-850L	TZXS-1000L	TZXS-1200L
主电机功率 Main motor power	11/15	11/15	30/22
送料风机功率 Power of feeding fan	4/5.5	5.5/7.5	5.5/7.5
牵引机功率 Tractor power	1.5	1.5/2.2	2.2/3.7
定刀的数量 Number of fixed knives	4	4	4
回转刀的数量 Number of rotary knives	24	36	36
粉碎室的口径 Diameter of crushing chamber	850*310	1000*310	1200*310
最大的粉碎量 Maximum crushing amount	400-600	400-800	800-1200
破碎时的噪音 Noise during crushing	70-100	70-100	70-100
筛网孔径 Mesh size	8/10/12	8/10/12	8/10/12
机器尺寸 Machine dimensions	1620*1260*2400	2000*1260*2350	2000*1260*1800

* 产品规格若有变更，恕不另行通知。
Wereserverighttochangespecifications without prior notice.

适用范围 Applicable scope

适用于粉碎的塑料产品：PP、PET、PS、PVC、PLA、生物基料等一次性塑料制品、食品包装、塑料吸塑托盘、塑料吸塑包装。

Applicable to crushed plastic products: PP, PET, PS, PVC, PLA, bio based materials and other disposable plastic products, food packaging, plastic blister tray, plastic blister packaging.

环保静音型破碎机

Environment Soundproof Type Crusher

功能特点 Functional Features

- ◆ 全封闭静音设计，机台周围1米范围外噪音在85db以下，同时避免了粉尘污染，是一款性能良好的环保型破碎机。
- ◆ 可根据需要定制双进料口，一机多用，调废卷料无需人工切片，可自动上卷料自动破碎作业。
- ◆ 可选配输送带上散料和两个吨袋自由切换，前后两个进料口投料，使破粉作业更轻松便捷，高效安全。
- ◆ 箱体内部通水冷却效果好，隔音棉设计，外观整洁，更有效把噪音隔绝在内。
- ◆ Fully enclosed silent design, the noise level within 1 meter around the machine is below 85db, and dust pollution is avoided. It is an environmentally friendly crusher with good performance.
- ◆ Double feed ports can be customized according to needs, one machine can be used for multiple purposes, and the waste coils can be automatically loaded and crushed without manual slicing.
- ◆ Optional conveyor belt for free switching between bulk materials and two ton bags, and two feeding ports at the front and rear to feed materials, making the powder breaking operation easier, more convenient, efficient and safer.
- ◆ The water cooling effect is good inside the box, and the sound insulation cotton design makes the appearance clean and more effective in isolating the noise inside.

适用范围 Scope of Application

适用粉碎回收PET、PETG、GAG、PVC、PP、PS、PC等胶片，吸塑、注塑吹塑边角料等塑料件。

Suitable for crushing and recycling PET, PETG, GAG, PVC, PP, PS, PC and other films, blister, injection molding, blow molding scraps and other plastic parts.



台彰机械还可提供一系列配套的辅助设备，如输送带，粉尘分离装置，金属探测器等。

Taizhang Machinery can also provide a series of supporting auxiliary equipment, such as conveyor belts, dust separation devices, metal detectors, etc.

技术参数 Technical Parameter

型号 Model	功率 Power (kW)	口径 Caliber (mm)	回旋直径 Tactical diameter	牵引电机 Traction motor (kW)	平刀 Flat knife	粉碎能力 Crushing capacity (kg/H)	尺寸 Size L*W*H (cm)	重量 Weight (kg)
TZP-800	22	800*500	415	1.5kw	4*24	500-700	185*160*240	2200
TZP-1000	37	1000*500	415	1.5kw	4*30	800-1000	200*175*260	3200
TZP-1200	45	1200*500	415	2.2kw	4*36	900-1500	210*200*260	4500
TZP-1500	45	1500*500	415	2.2kw	4*15	1000-1600	230*220*260	5500

* 产品规格若有变更，恕不另行通知。
Wereserverighttochangespecifications without prior notice.

重工爪刀型破碎机

Claw Knife Type Crusher

功能特点 Functional Features

- ◆ 爪型粉碎机适用于各种塑料之粉碎再利用，尤其对各类硬性塑料（如料头、鞋楦料等）效果更佳。粉碎机操作方便，换刀简单快捷；刀架优化设计，爪型刀可分散受力度，使得每片刀的剪切加大，适合粉碎厚材料，硬质料块，料头等，有效的提高了刀具切削力、减少刀具磨损；设有电控安全设计，料斗采用双层结构，内填隔音材料，使得设备具有良好的安全性及环保性，省电耐用。
- ◆ 反爪式设计，刀刃受力更小，破碎物料时，受力点转移至刀背；
- ◆ 爪型剃刀式设计，抓力更好，受力更均匀，破碎物料更轻松；
- ◆ 整机采用加厚型钢板焊接制作；粉碎转子为实心钢板材料（非铸件）；
- ◆ 粉碎腔采用加厚钢板，精铣倒角后整体焊接成形；焊接部位研磨平整，做工精细，内腔光滑平整；
- ◆ 采用进口刀具，刀片硬度与韧性更好，更耐用。

设计独特的刀具 Unique Tool Design

刀架优化结构设计，爪型刀可分散受力度，使得每片刀的剪切力加大，适合破碎厚材料，硬质料块、胶头等，有效的提高了刀具切削力、减少刀具磨损。

The optimized structure design of the tool holder allows the claw shaped knife to disperse the force, increasing the shear force of each blade. It is suitable for crushing thick materials, hard blocks, rubber heads, etc., effectively improving the cutting force of the tool and reducing tool wear.

- ◆ The claw type crusher is suitable for crushing and reusing various plastics, especially for various hard plastics (such as material heads, shoe lasts, etc.) with better results. The grinder is easy to operate and the tool change is simple and fast; The optimized design of the tool holder allows the claw shaped knife to disperse the force, increasing the shear force of each blade, making it suitable for crushing thick materials, hard blocks, material heads, etc., effectively improving the cutting force of the tool and reducing tool wear; Equipped with electronic control safety design, the hopper adopts a double-layer structure and is filled with soundproofing materials, making the equipment have good safety and environmental protection, energy-saving and durable.
- ◆ Anti claw design, with less force on the blade. When crushing materials, the force point is transferred to the back of the blade;
- ◆ Claw shaped razor design, better grip, more uniform force, and easier material crushing;
- ◆ The entire machine is made by welding thickened steel plates; The crushing rotor is made of solid steel plate material (not cast iron);
- ◆ The crushing chamber is made of thickened steel plates, which are finely milled and chamfered before being welded as a whole; The welding parts are ground flat, with fine workmanship, and the inner cavity is smooth and flat;
- ◆ Using imported cutting tools, the blade has better hardness and toughness, making it more durable.



可自由混搭 Free to mix and match



旋风分离回收装置
Cyclone Separation and Recovery Unit



粉尘分离收集系统
Dust separation and collection system



输送带
Conveyor Belt

技术参数 Technical Parameter

型号 Model	口径 Caliber (mm)	电机 Motor (kW)	爪刀型 Claw knife (pcs)	平刀型 Flat knife (pcs)	八字刀 Eight character knife (pcs)	产量 Yield (kg/H)	尺寸 Size L*W*H (mm)	重量 Weight (kg)
TZG-10HP	400*250	7.5	2*21	2*6	/	150-400	110*850*1250	590
TZG-20HP	460*300	15	2*27	2*6	/	300-600	1400*1000*1500	950
TZG-30HP	570*400	22	2*27	2*9	2*6	700-1000	1500*1160*1750	1700
TZG-50HP	730*550	37	2*27	2*6	2*9	800-1200	1800*1420*2071	3200
TZG-75HP	960*630	55	4*36	4*6	4*9	850-1300	2100*1715*2550	3800
TZG-100HP	1200*700	75	4*42	4*6	4*12	1000-1500	2300*2000*2850	4550

* 产品规格若有变更，恕不另行通知。
Wereserverighttochangespecifications without prior notice.

适用范围 Scope of Application

适用于各种塑料粉碎再利用，尤其对各类硬性塑料（料头，板材，管材等）效果更佳。

It is suitable for all kinds of plastics to be pulverized and reused, especially for all kinds of rigid plastics (head, plate, pipe, etc.)

片材边料粉碎机

Sheet Edge Shredder



功能特点

Functional Features

送料风机部分 Feeding fan

- ◆ 送料风机底座由国标角铁焊接而成。同时采用名牌厂家的马达，质量稳定，经久耐用。
- ◆ 风机外壳及叶片采用不锈钢制作，美观大方、永不生锈、环保卫生、坚固耐用。
- ◆ 独特的风叶设计，增加了风压，输送物料能力强且运行稳定。
- ◆ The base of the feed fan is welded by the national standard angle iron, At the same time, it adopts the motor of the famous brand manufacturer, the quality is stable, and it is durable.
- ◆ The fan shell and blades are made of stainless steel, which is beautiful and generous, never rusty, environmentally friendly and sanitary, strong and durable.
- ◆ The unique fan blade design increases the wind pressure, has strong material conveying capacity and stable operation.

牵引部分 Traction part

- ◆ 牵引主轴采用高强度无缝钢管精密加工，再镀硬铬，美观大方，永不生锈，坚固耐用，符合环保。
- ◆ 机体是由国标钢精密加工制成，美观大方，坚固耐用。
- ◆ 动力部分采用名牌厂家齿轮减速马达，全新一体化设计，方便轻巧，坚固耐用，并配备名牌厂家的变频器，可与主机同步使用，速度可以满足不同客户的需求，质量稳定。
- ◆ The traction spindle is precision processed with high-strength seamless steel pipe, and then plated with hard chrome, which is beautiful and generous, never rusty, durable, and environmentally friendly.
- ◆ The body is made of precision machining of national standard steel, which is beautiful and durable.
- ◆ The power part adopts the gear reduction motor of the famous brand manufacturer. The new integrated design is convenient and light, strong and durable. It is equipped with the frequency converter of the famous brand manufacturer, which can be used in synchronization with the host. The speed can meet the needs of different customers and the quality is stable.

粉碎机部分 Crusher part

- ◆ 刀具采用名牌厂家的特殊钢制造而成，硬度高、韧性好、耐磨性强，特别坚固耐用，便于粉碎各种不同的软硬料，破碎能力强。
- ◆ 机体采用优质钢板焊接加工而成，坚固耐用，永不爆裂。
- ◆ 机架采用国标槽钢焊接而成，并配有螺丝固定装置，保持机器的稳定性。
- ◆ 刀架采用空心式结构设计，运转稳定，风阻小，散热快，且坚固耐用。
- ◆ 轴承采用名牌厂家的轴承，稳定、耐用。飞轮、皮带轮经过精细铸造，精密加工而成，坚固耐用。
- ◆ 采用同步皮带传动方式，技术成熟，运作稳定。
- ◆ 操作简单，性能可靠，低噪音，高质量。
- ◆ 粉碎原料的厚度范围为0.5-3mm。(如需粉碎加厚材料,请订购时加以注明。)
- ◆ The knives are made of special steel made by famous brand manufacturers, with high hardness, good toughness, strong wear resistance, especially strong and durable, easy to crush various soft and hard materials, and strong crushing ability.
- ◆ The machine body is welded and processed with high-quality steel plates, which is sturdy and durable. and will never burst.
- ◆ The frame is welded with national standard channel steel and is equipped with screw fixing devices to maintain the stability of the machine.
- ◆ The tool holder adopts hollow structure design, stable operation, low wind resistance, fast heat dissipation, and sturdiness and durability.
- ◆ The bearing adopts the bearing of famous brand manufacturer, which is stable and durable. The flywheel and belt pulley are made of precision casting and precision processing, which are strong and durable.
- ◆ It adopts synchronous belt transmission mode, mature technology and stable operation.
- ◆ Simple operation, reliable performance, low noise and high quality.
- ◆ The thickness of the crushed raw material ranges from 0.5 to 3 mm. (If you need to crush thickened materials, please specify when ordering).



产品描述

Product Description

片材在线破碎机主要适用于与片材挤出机配套使用。为了使得边料在生产的同时保持干净、干燥，粉碎料经风机(或吸料机)立即吹送到挤出机入料口位置，经小型螺杆送料机与主螺杆一起将新料、旧料压送成型循环利用，从而达到100%回收耳料。

Sheet edge shredder is mainly suitable for matching with the sheet extruder. In order to keep the edge materials clean and dry during production, the crushed materials are immediately blown to the feed port of the extruder through the fan (or suction machine), and the new and old materials are pressed together with the main screw through the small screw feeder to form and recycle, so as to achieve 100% recovery of ear materials.

技术参数

Technical Parameter

型号 Model	TZB-300	TZB-400
主电机功率 Main motor power	4/5.5	5.5/7.5
送料风机功率 Power of feeding fan	3/4	3/4
牵引机功率 Tractor power	0.75/0.4	0.75
定刀的数量 Number of fixed knives	2	2
回转刀的数量 Number of rotary knives	3	6
粉碎室的口径 Diameter of crushing chamber	300*180	400*180
最大的粉碎量 Maximum crushing amount	80-100	100-200
破碎时的噪音 Noise during crushing	70-100	70-100
筛网孔径 Mesh size	8/9.5/10.5/12	8/9.5/10.5/12
机器尺寸 Machine dimensions	1325*920*1385	1325*920*1385

* 产品规格若有变更，恕不另行通知。
Wereserverighttochangespecifications without prior notice.

适用范围

Applicable scope

适用于粉碎的产品：PP、PS、PVC、PLA、PET等两条塑料片材的边料。

Applicable to crushed products: leftovers of two plastic sheets such as PP, PS, PVC, PLA and pet.

片材成套辅机

Sheet Complete Set Of Auxiliary Machines

功能特点

Functional Features

- ◆ 整体墙板分段设计，方管焊接式辅机，方便打扫卫生及量胶片厚度和宽度(可根据客户要求定做方管焊接及铝型材框架)。
 - ◆ 整套辅机，长、宽、高可根据客户要求私人定制。
 - ◆ 可根据客户要求定制，切边机，收废边机，普通涂布及离端涂布机，烘箱长度，覆膜机，分切刀，牵引机，收卷机以及重型收卷机，实现全方位私人定制。
 - ◆ 适用胶片：PET、PETG、PP、PS等。
-
- ◆ The overall wall panel is designed in sections, and the square tube welding auxiliary machine is convenient for cleaning and measuring the thickness and width of the film (square tube welding and aluminum profile frame can be customized according to customer requirements).
 - ◆ The length, width and height of the whole set of auxiliary machines can be customized according to customer requirements.
 - ◆ It can be customized according to customer requirements, including trimming machine, waste edge collecting machine, ordinary coating machine and off-end coating machine, oven length, laminating machine, slitting knife, traction machine, winder and heavy winder, to achieve all-round private customization.
 - ◆ Applicable films: PET, PETG, PP, PS, etc.



螺杆、镜面辊筒、平模头修复改造

Repair and transformation of screw, mirror roller and flat die head



针对每一套翻新螺杆、镜面键筒、平模头我们都将严格按照以下步骤进行：

For each set of refurbished screw, mirror key, flat die head, we will strictly follow the following steps:

螺杆修复

主要针对扭转损坏和磨损损坏的螺杆进行修复。工序包括接、高镍合金热喷涂(耐磨或耐腐蚀处理)、氮化、纳等工序。

Screw repair

Mainly aimed at repairing screws damaged by twisting and wear. The processes include welding, high-nickel alloy thermal spraying (wear-resistant or corrosion-resistant treatment), nitriding, and nanoprocessing.

辊面辊筒修复

伤点局部修复：伤点修复、局能研磨、电镀、抛光镜面处理。整体修复：研磨去铭、电镀、抛光、超镜面处理。

Roller surface roller repair

Local repair of damaged spots: repair of damaged spots, local grinding, electroplating, polishing and mirror treatment. Overall repair: grinding and de-marking, electroplating, polishing, super mirror treatment.

平模头修复

提供系统式的清洗、检测、修复、并级、改造够服务，包括：

Flat die repair

Provide systematic cleaning, inspection, repair, upgrading and transformation services, including:

- 1、模头拆卸，清理
- 2、检查、评估，针对技术翻新要求与客户沟通
- 3、退除原始锻层
- 4、修复受损表面或更改缺陷设计
- 5、更换损坏部件
- 6、修复模体接合面
- 7、流道进行重新抛光
- 8、重新组装模头
- 9、校对各项技术指标

1. Dismantle and clean the die head
2. Inspection, evaluation, and communication with customers regarding technical renovation requirements
3. Remove the original forging layer
4. Repair damaged surfaces or change defective designs
5. Replace damaged parts
6. Repair the joint surface of the model
7. Re-polishing of the flow channel
8. Reassemble the roof
9. Check the technical indicators of each